



1. FAILURE TO FOLLOW THESE INSTRUCTIONS COULD CAUSE A HAZARDOUS CONDITION!
2. THE CENTER OF THE FIFTH WHEEL LOCKS MUST ALWAYS BE ON OR AHEAD OF THE TRACTOR REAR SUSPENSION CENTERLINE.
3. QUALIFIED WELDERS SHOULD PERFORM ALL WELDING. USE A PROCEDURE THAT DEVELOPS A QUALITY WELD AND PROTECTS THE TRACTORS ELECTRICAL SYSTEM.
JOIST RECOMMENDS A LOW HYDROGEN PROCESS AND AWS E70XX FILLER METAL. DO NOT WELD ON FIFTH WHEEL TOP PLATE.
4. THE FIFTH WHEEL LOCKING MECHANISM IS FACTORY ADJUSTED; DO NOT RE-ADJUST.
5. AFTER INSTALLATION PULL RELEASE HANDLE TO UNLOCKED POSITION AND CHECK FOR PROPER OPERATION BEFORE USE; DO NOT USE ANY FIFTH WHEEL WHICH FAILS TO OPERATE PROPERLY.
6. USE ONLY WITHIN RATED CAPACITIES AND IN CONJUNCTION WITH SAE KINGPINS AND TRAILER UPPER COUPLERS.

GENERAL RECOMMENDATIONS:

1. INSTALLATION PROCEDURES:

The installer may wish to consult other installation recommendations such as the TMC recommended practice RP603B, the OEM Tractors' Body Builders Book or the latest SAE and DOT standards.

2. MOUNTING ANGLES:

- a. Select the proper location for the fifth wheel (see WARNING #2 above). For assistance in determining the proper position, request publication LT SKAPG-01.
- b. The mounting angle material should be ASTM A36 minimum with a minimum thickness of 5/16" and minimum length of 36".
- c. Mounting bolts should be placed between 1" and 1 1/2" from edges and cutouts. If cutouts are required, they should have a minimum radius of 1".
- d. Bolt holes can be 1/32" larger than the fasteners. Bolt spacing should not exceed 8".
- e. Chamfer or smooth sharp edges wherever contact is made with the tractor frame.
- f. The mounting angle must be attached so that the full length of the mounting angle seats flush with the top and side surfaces of the tractor frame with no gaps.
- g. When mounting to aluminum frame rails or using aluminum mounting angles follow the tractor manufacturer's recommendations.

3. MOUNTING BOLTS:

- Use a minimum of 5 – 5/8" diameter grade "8" bolts with grade "C" locknuts to attach each mounting angle.
- Hardened flat washers should be placed under both the bolt and locknut unless flanged head bolts and locknuts are employed.
- Torque all fasteners to the bolt manufacturer's recommendations.
- The bolt spacing should not exceed 8" except where cutouts are required.

4. TILT STOPS:

- Rearward tilt stops are recommended to hold the ramps of the fifth wheel top plate above the top of the vehicle frame.
- The tilt stop should be positioned to hit the top plate casting on the stud provided (see figure #1).

5. PICK-UP RAMPS:

- Pick-up ramps are recommended to assist in moving the trailer onto the fifth wheel for coupling.
- The pick-up ramp should be at least 3" wide and welded to a mounting angle, which is bolted to the tractor frame.
- Placing a straight edge on the fifth wheel top plate when the top plate is articulated to the rear should develop the shape of the pick-up ramp (see figure #2). The rear of the tractor frame should be tapered to match this profile, provided the strength of the frame and suspension members is not compromised.
- When developing the shape of a pick-up ramp for sliding fifth wheels the profile must be generated in both the forward and rear positions.
- All pick-up ramps should have a minimum 4" flat at the top to avoid damage to the trailer upper coupler (see figure #2).

FIGURE #1

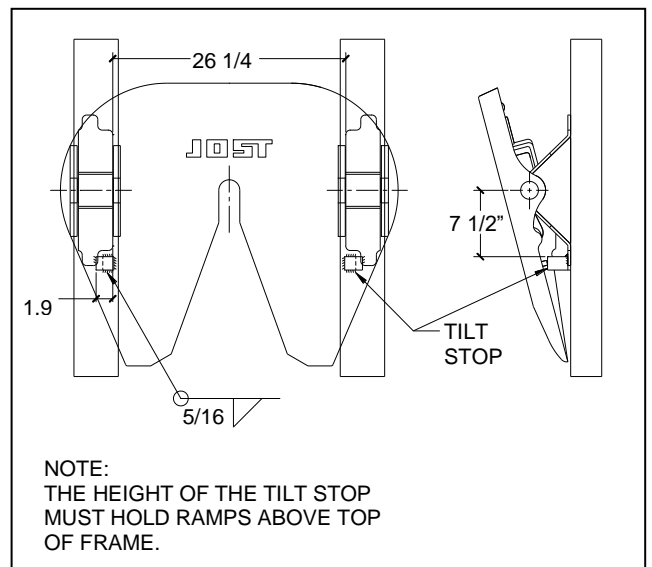
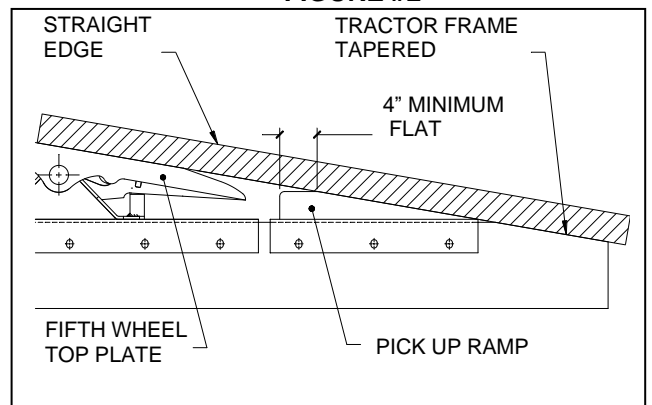

FIGURE #2



ADDITIONAL SPECIFIC RECOMMENDATIONS FOR STATIONARY FIFTH WHEEL MOUNTINGS:

1. INBOARD ANGLE:

- The mounting angle should extend a minimum of 18" forward and not less than 12" to the rear of the pivot point.
- The bracket width must be ordered to match the tractor frame width.

2. BRACKET FOR ANGLE MOUNTING:

- a. If a bracket for angle mounting is selected, locate and clamp the mounting angles first, then locate the fifth wheel and brackets onto the mounting angles. Next, securely tack weld the bracket to the mounting angles and check for free articulation of the fifth wheel. Remove the brackets and weld (see figure #3). Weld the brackets to the mounting plate as instructed in figure #3.
- b. The bracket for angle mounting can be attached to a flat plate instead of mounting angles. The mounting plate should have a minimum thickness of 5/16". Weld the brackets to the mounting plate as instructed in figure #3.

3. OUTBOARD ANGLE-PLATE MOUNT:

- a. Plate Mount brackets are intended to be mounted on either flat or corrugated mounting plates.
- b. Use a mounting angle with a minimum 3" horizontal and 3 1/2" vertical leg.
- c. When using a flat plate, it is recommended to add an inside angle as shown in figure #4

ADDITIONAL SPECIFIC RECOMMENDATIONS FOR SLIDING FIFTH WHEEL INSTALLATIONS:

1. INBOARD ANGLE MOUNTING:

The Inboard Slider comes with the mounting angles attached for a specific frame width. (See figure #5)

2. OUTBOARD ANGLE MOUNTING:

- a. The full length of the mounting angles must be flush with the top of the tractor frame to provide uniform weight distribution.
- b. Attach the slide plate to the mounting angles, make certain to use every mounting hole provided in the slide plate. (See figure #6)

FIGURE #3

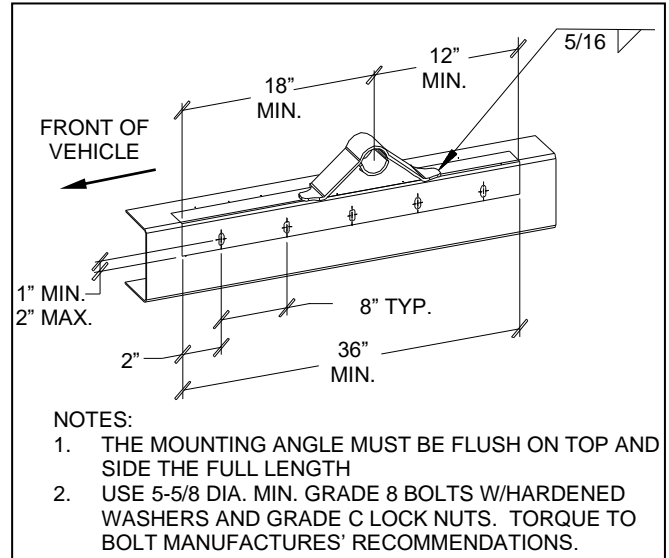

FIGURE #4

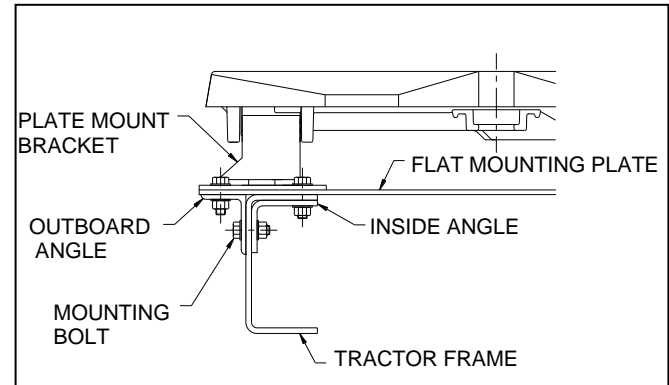

FIGURE #5

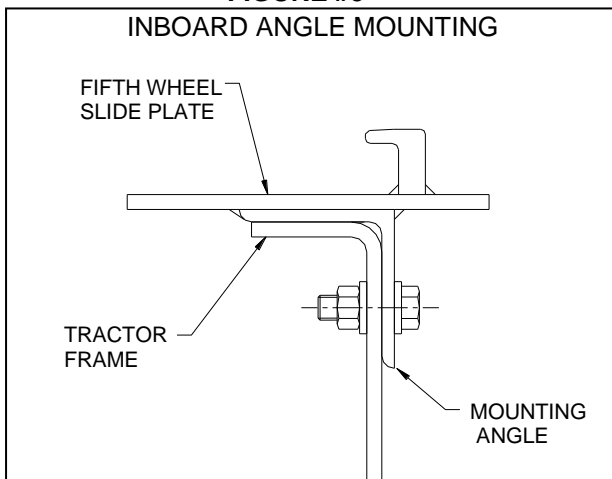
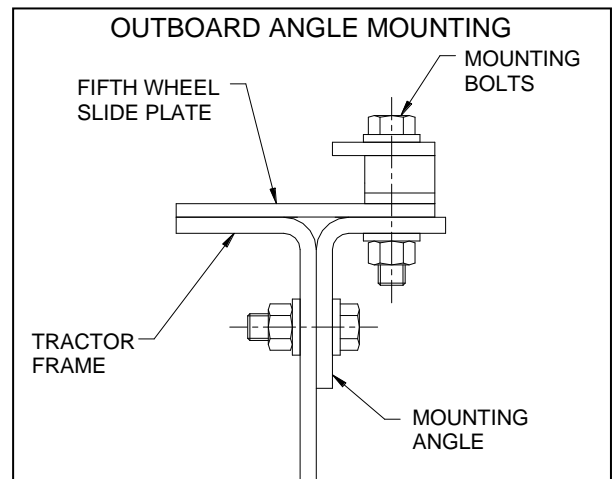

FIGURE #6



ATTACHMENT OF AIR SLIDE RELEASE – IF REQUIRED:

1. Mount the cab control valve. It should be accessible to the driver but protected to avoid accidental activation.
2. Attach an airline to the “IN” port of the valve. Use an air source recommended by the tractor manufacturer.
3. Attach an airline to the “OUT” port of the valve.
4. Attach the other end of the airline to a bulkhead fitting. Locate the bulkhead fitting in a position at the front of the slide plate that will not interfere with any other operation.
5. Attach a coiled air hose of suitable length between the bulkhead fitting and the air cylinder.
6. Support the air hose using wire ties to avoid damage during sliding.
7. Check the operation of the air cylinder and slide mechanism making certain that the mechanism unlocks and relocks securely.

INSPECTION AND LUBRICATION:

1. Inspect the installation. Make certain all fasteners are installed and properly tightened. Review the installation procedures; make certain all steps are completed.
2. Inspect bracket pin bolts, make sure locking tabs are properly securing the bolts in place (see figure #7A & #7B).
3. Check the locking mechanism using a lock tester as described in the Maintenance Procedure (LT SK37U-03).
4. Apply grease containing “extreme pressure additives” to the top of the fifth wheel plate.

FIGURE #7A

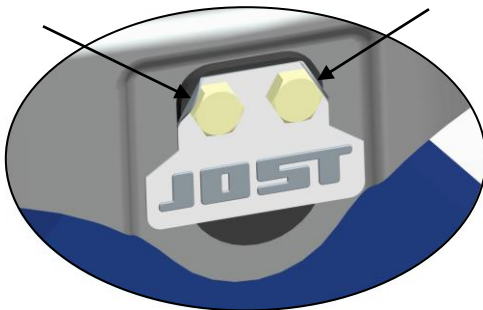
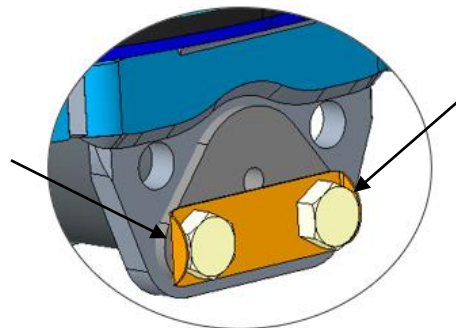

FIGURE #7B



Locking tabs properly securing bolts