



UL550 Series Landing Gear

Weight Savings of at Least 27 lbs Per Set!
Same Trusted Design, New Lightweight Material



Design Features

- No maintenance needed, under normal conditions, for the first 10 years.
- Increased lift nut hardness to increase strength and reduce wear.
- HSLA material on both the upper and lower tube provides low weight and increased strength.
- Elevating screw is fully encased in a rechargeable grease tube.
- Legs are completely sealed and all shafts have seals to keep moisture out.
- Hole added to lower leg to access grease fitting in rechargeable grease tube.
- Replaceable cushion foot for easy repair when worn or damaged.
- Removable Cushion Foot
- Double "D" style shaft allows crank force to go directly into the gearbox, not torquing the bolt.

Capacities & Ratings

Maximum Static Load Rating*
170,000 lbs

Rated Lift Capacity**:
57,500 lbs

Side Load Capacity*:
33,000 lbs per set

*When properly braced on a trailer.

**With 100ft-lbs input torque.

Gear Ratio

Low Gear: 32 Turns = 1" Travel

High Gear: 3.5 Turns = 1" Travel

High Gear

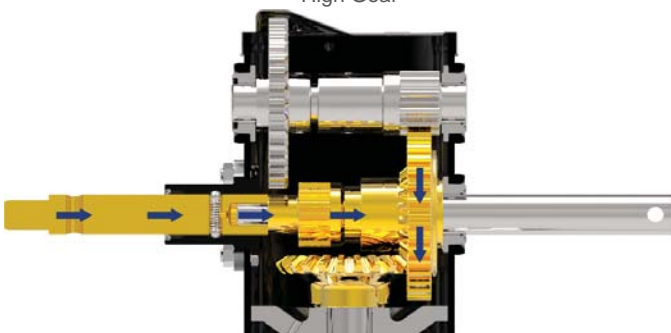

Low Gear

