

SAE Mushroom Style Kingpin



SAE kingpins are suitable for OEM and aftermarket replacement. They are intended to be installed by welding, using a procedure published by the American Welding Society or other technical organization. When properly installed they will meet or exceed the performance requirements of the Society of Automotive Engineers (SAE) and the Truck and Trailer Manufacturers Association (TTMA).



Technical Specifications

- **MATERIAL – AISI 8630H**
- **HEAT TREATMENT**
Through hardened using a quenched and temper process, which produces a surface hardness of 302-363 BHN.
- **STRENGTH**
At the above hardness the material will have an approximate 150,000 p.s.i. ultimate strength and 115,000 p.s.i. yield strength.
- **IMPACT AND WEAR RESISTANCE**
The high nickel alloy and heat treat process provides a good balance between hardness (wear resistance) and low brittleness (good impact resistance).
- **QUALITY ASSURANCE**
Rigid metallurgical cleanliness and quality standards including:
 - 100% Brinell Hardness testing.
 - 100% magnetic particle inspection.
 - 100% ultrasonic testing (MS105, tightened C = 0).

Mushroom Style - 8630H Steel Forging

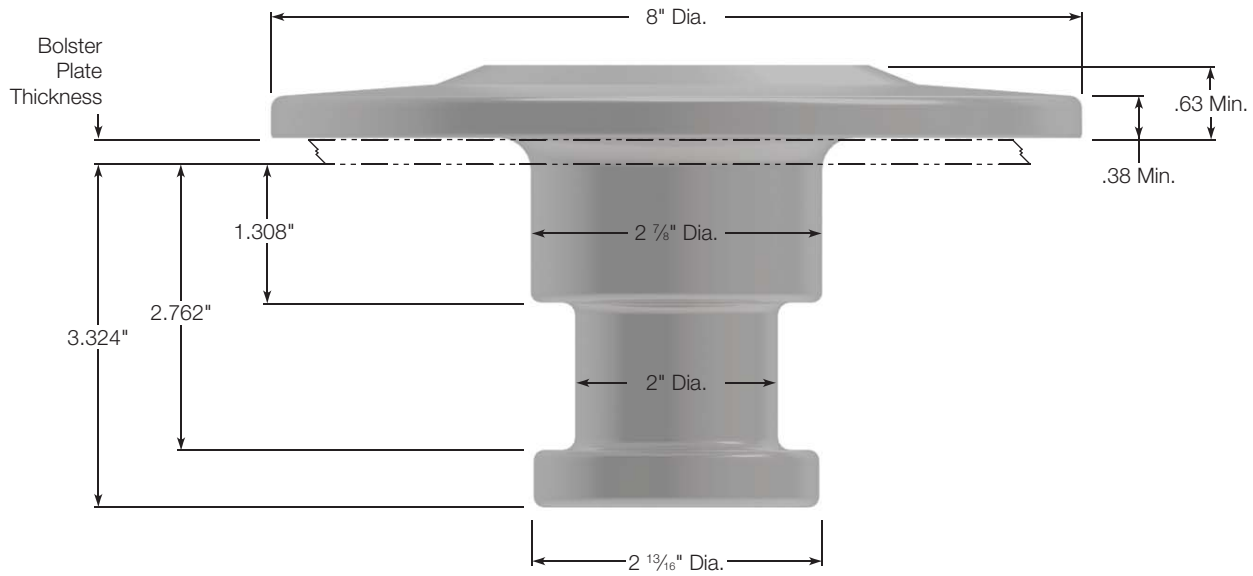

Part Number	Bolster Plate Thickness	Weight
KZ-T2	1/4"	14 lbs.
KZ-T3	5/16"	14 lbs.
KZ-T4	3/8"	14 lbs.
KZ-T5	1/2"	14 lbs.
KZ-T6	5/8"	14 lbs.