

Your **JOST** fifth wheel has been designed and manufactured to provide years of trouble free service. These procedures cover only the fifth wheel operation. It is important to follow each step of these instructions.

COUPLING PROCEDURES

A. INSPECT THE FIFTH WHEEL

1. The ramps must be tilted down (see figure 1).
2. The locks must be open.
3. The fifth wheel must be lubricated.

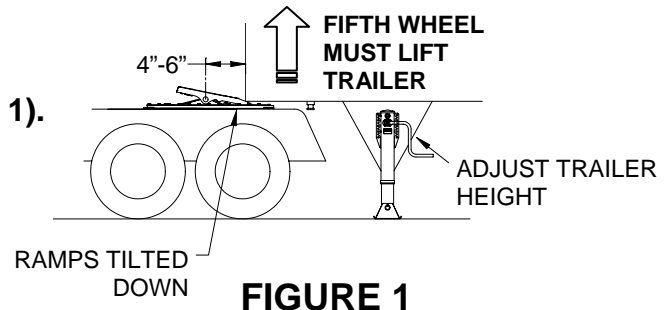

B. PREPARE THE TRAILER

1. Back up close to trailer centering kingpin on fifth wheel.
2. Block trailer wheels.
3. Connect air lines and light cord.
4. Set trailer brakes.
5. Adjust the trailer height (if reqd.). The trailer should contact the fifth wheel approx. 6" behind pivot.

IMPORTANT! When coupling, the fifth wheel must pick up the trailer (see figure 1).



**ATTEMPTING TO COUPLE AT THE WRONG HEIGHT
MAY CAUSE IMPROPER COUPLING, WHICH COULD
RESULT IN DAMAGE OR PERSONAL INJURY!**

C. COUPLE TRAILER

1. Back under trailer.
2. After picking up trailer, **STOP** (stopping prevents hitting the kingpin too hard).
3. Continue backing until fifth wheel locks.
4. Pull forward to test the coupling as an initial check.



WARNING

A VISUAL INSPECTION IS REQUIRED BY LAW. SOME IMPROPER COUPLINGS CAN PASS A PULL TEST. SOUND IS NOT RELIABLE. GET OUT OF THE CAB AND LOOK.

D. VISUAL INSPECTION

1. Check that there is **NO GAP** between the trailer bolster and the fifth wheel (see figure 2).
2. Check that the **KINGPIN** is **INSIDE** the **LOCK** (see figure 2).
3. Check that the release **HANDLE** is **INSIDE** the **NARROW SLOT** (see figure 3).

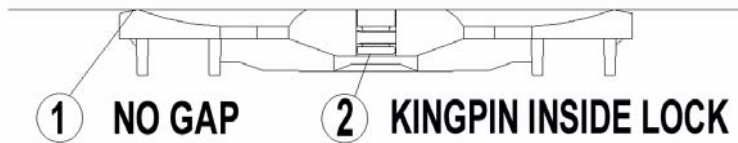

FIGURE 2



FIGURE 3

UNCOUPLING PROCEDURES

A. PREPARE FOR UNCOUPLING

1. Uncouple in a location that provides support for the landing gear.
2. Set trailer brakes.
3. Back into kingpin and set tractor emergency brake.
4. Block trailer wheels.
5. Lower trailer landing gear until they touch the ground. Shift to low gear and crank a few extra turns.
6. Disconnect the brake lines and light cord.

B. UNCOUPLING

1. Unlock the fifth wheel:
Lift release handle up into wide slot and move forward while pulling handle out (see figure 4). Lock handle in open position using notch provided.
2. Release the tractor emergency brake and pull out slowly allowing the trailer to slide down the fifth wheel and pick up ramps.

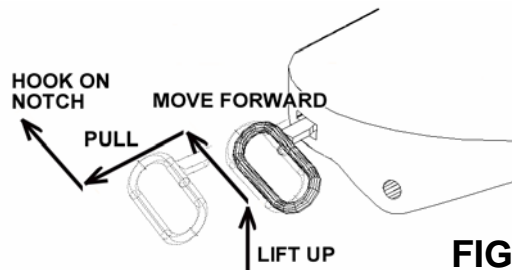

FIGURE 4